

University of Groningen

Complementarity and passivity for piecewise linear feedback systems

Iannelli, Luigi; Vasca, Francesco; Camlibel, Kanat

Published in:
Proc. of the 45th IEEE Conference on Decision and Control

IMPORTANT NOTE: You are advised to consult the publisher's version (publisher's PDF) if you wish to cite from it. Please check the document version below.

Document Version
Publisher's PDF, also known as Version of record

Publication date:
2006

[Link to publication in University of Groningen/UMCG research database](#)

Citation for published version (APA):
Iannelli, L., Vasca, F., & Camlibel, K. (2006). Complementarity and passivity for piecewise linear feedback systems. In *Proc. of the 45th IEEE Conference on Decision and Control* (pp. 4212-4217). IEEE (The Institute of Electrical and Electronics Engineers).

Copyright

Other than for strictly personal use, it is not permitted to download or to forward/distribute the text or part of it without the consent of the author(s) and/or copyright holder(s), unless the work is under an open content license (like Creative Commons).

The publication may also be distributed here under the terms of Article 25fa of the Dutch Copyright Act, indicated by the "Taverne" license. More information can be found on the University of Groningen website: <https://www.rug.nl/library/open-access/self-archiving-pure/taverne-amendment>.

Take-down policy

If you believe that this document breaches copyright please contact us providing details, and we will remove access to the work immediately and investigate your claim.

Downloaded from the University of Groningen/UMCG research database (Pure): <http://www.rug.nl/research/portal>. For technical reasons the number of authors shown on this cover page is limited to 10 maximum.

Complementarity and passivity for piecewise linear feedback systems

Luigi Iannelli and Francesco Vasca

Dipartimento di Ingegneria
 Università del Sannio di Benevento
 Piazza Roma, 21, 82100 Benevento, Italy
 {luigi.iannelli, vasca}@unisannio.it

Kanat Camlibel

Department of Mechanical Engineering
 Eindhoven University of Technology
 P.O. Box 513, 5600 MB Eindhoven, The Netherlands
 k.camlibel@tue.nl

Abstract—Piecewise linear feedback systems composed by a dynamical linear time invariant system closed in feedback through a static piecewise linear mapping are considered. By representing the closed loop system in the affine complementarity form, passivity is exploited in order to prove existence of absolute continuous solutions and stability of the equilibria. Assuming passivity of the open loop system and using results on equivalent circuit representations of piecewise linear mappings, conditions on the static feedback connection for preserving passivity in closed loop, are proposed and discussed.

I. INTRODUCTION

Piecewise Linear (PWL) systems have been widely studied in the literature. Within this class, we consider piecewise linear feedback systems as the feedback interconnection of a linear dynamical system Σ_d with a piecewise linear static characteristic, as reported in Figure 1. Σ_d represents the linear system with (A_d, B_d, C_d, D_d) being a minimal state space realization, $A_d \in \mathbb{R}^{n \times n}$, $B_d \in \mathbb{R}^{n \times m}$, $C_d \in \mathbb{R}^{m \times n}$, and $D_d \in \mathbb{R}^{m \times m}$. The static characteristic $\varphi(\lambda) : \mathbb{R}^m \mapsto \mathbb{R}^m$ is a piecewise linear multi-valued mapping, which includes piecewise linear functions (Figure 2(a)), set-valued functions (Figure 2(b-d)) and unbounded characteristics (Figure 2(c-d)).

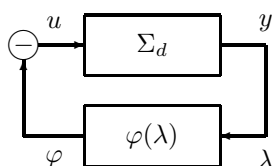

Fig. 1. The closed loop class of system under consideration.

Even basic questions like the well-posedness and stability in this class of nonsmooth dynamical systems, are far to be easily answered [1], [2]. Several particular cases of such problem have been considered in the literature. If the static characteristic φ is at least locally Lipschitz then the whole closed loop system has a Lipschitz vector field and standard results on existence and uniqueness of solutions apply. Moreover, if $\varphi(0) = 0$ and if $u = -\varphi(C_d x + D_d u)$ has a unique solution for any x , then the classical absolute stability problem can be considered [3]. If the static characteristic φ is not Lipschitz, possibly discontinuous or even a set-valued function, proving well-posedness is a non trivial task.

This work was supported by the European Commission within the SiCONOS project IST2001-37172 and the Marie Curie project MTKD-CT-2004-003107.

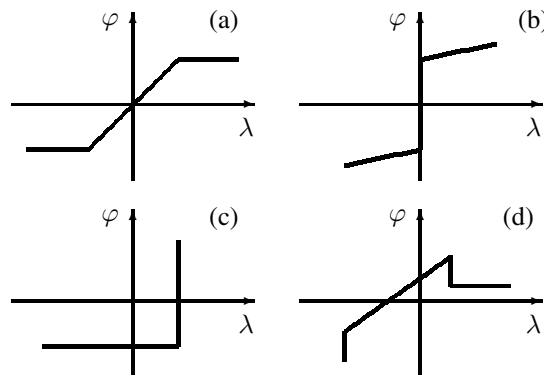

Fig. 2. Piecewise linear mappings (one-dimensional case).

Filippov's work on discontinuous differential equations [1] deal with such kind of systems, although in that framework unbounded characteristics like that in Figure 2(c-d) cannot be considered. The particular case in which the linear system Σ_d is strictly proper and strictly passive and φ is a set-valued mapping, has been studied in [4] where well-posedness and the absolute stability problem are solved. Anyway in that paper it is required that the set-valued mapping φ is nondecreasing (the term *monotone* is used) and passing through the origin. If Σ_d is not strictly proper but it is still passive and φ represents complementarity relations between y and u , the results in [5] can be used to conclude well-posedness with the forward solution concept.

In our paper we will use the linear complementarity systems framework [6], [7] in order to extend the existing results to the case with $D_d \neq 0$, Σ_d not necessarily passive, and φ any piecewise linear set-valued mapping, not necessarily passing through the origin neither lying in the first and third orthant. We only require that $\varphi(\cdot)$ can be represented by using the complementarity formalism and that the corresponding complementarity closed loop model Σ satisfies some passivity conditions. By exploiting the passivity concept on the class of affine complementarity systems, conditions for well-posedness and stability are presented.

An equivalent electrical circuit approach [8] is proposed for constructing a model of the feedback characteristic in the complementarity formalism. Such representation is exploited in order to derive passivity of the closed loop system Σ when starting from a passive open loop system Σ_d , showing that passivity is preserved for any nondecreasing possibly set-valued feedback characteristic.

II. PRELIMINARIES

This section presents some facts about linear complementarity problems [9].

Problem 1 (LCP(q, L)): Given $q \in \mathbb{R}^p$ and $L \in \mathbb{R}^{p \times p}$, find $z \in \mathbb{R}^p$ such that

$$z \geq 0 \quad (1a)$$

$$q + Lz \geq 0 \quad (1b)$$

$$z^T(q + Lz) = 0, \quad (1c)$$

where the inequalities are considered componentwise.

Definition 1: A matrix $L \in \mathbb{R}^{p \times p}$ is called a P -matrix if all its principal minors are strictly positive.

According to the definition, every positive definite matrix is a P -matrix but the converse is not true.

Theorem 1: [9, Theorem 3.3.7] Let $L \in \mathbb{R}^{p \times p}$ be given. Then the LCP(q, L) has a unique solution for any $q \in \mathbb{R}^p$ if and only if L is a P -matrix.

Now we will introduce some definitions that will be used in the Section IV-A.

Definition 2: Let us denote the set of solutions of the LCP($0, L$) by \mathcal{Q}_L :

$$\mathcal{Q}_L = \{z | z \geq 0, Lz \geq 0, z^T Lz = 0\}. \quad (2)$$

Definition 3: Let be \mathcal{Q} a nonempty set of \mathbb{R}^p . Then the dual set of \mathcal{Q} is the set

$$\mathcal{Q}^* = \{w \in \mathbb{R}^p | w^T z \geq 0 \forall z \in \mathcal{Q}\}. \quad (3)$$

We now introduce the concept of a complementarity system, i.e. a linear system whose dynamics must satisfy a LCP for each time instant.

Definition 4: An affine complementarity system (ACS) is the following affine system subject to complementarity constraints of z and w variables:

$$\dot{x} = Ax + Bz + g \quad (4a)$$

$$w = Cx + Dz + h \quad (4b)$$

$$0 \leq w \perp z \geq 0, \quad (4c)$$

where $g \in \mathbb{R}^n$, $h \in \mathbb{R}^p$ are constant vectors, $x \in \mathbb{R}^n$, $z \in \mathbb{R}^p$, $w \in \mathbb{R}^p$ are vector functions of the time and A, B, C, D are matrices of suitable dimensions.

It appears evident how the LCP($Cx + h, D$) must be feasible for each time instant t since its solution $z(t)$ (that might exists or not, can be discontinuous or even impulsive, etc.) affects the dynamics. Existence of solutions in such nonsmooth systems are not a trivial problem [5], [10], [11].

Finally we present one definition [3] of passivity for a linear dynamical system:

Definition 5: The following linear dynamical system, denoted by $\Sigma(A, B, C, D)$,

$$\dot{x} = Ax + Bu \quad (5a)$$

$$y = Cx + Du, \quad (5b)$$

is said to be passive if there exists a continuously differentiable positive semidefinite function $V(x)$ (called the *storage*

function) such that

$$u^T y \geq \dot{V} \triangleq \left(\frac{\partial V}{\partial x} \right)^T (Ax + Bu) \quad \forall (x, u). \quad (6)$$

Moreover, it is said to be strictly passive if

$$u^T y \geq \dot{V} + \psi(x) \quad \forall (x, u), \quad (7)$$

for some positive definite function $\psi(x)$.

By using the well-known Kalman-Yakubovich-Popov Lemma [3] it can be shown that the passivity of $\Sigma(A, B, C, D)$ is equivalent to the feasibility of the following linear matrix inequality (LMI):

$$\begin{pmatrix} A^T P + PA & PB - C^T \\ B^T P - C & -D - D^T \end{pmatrix} \leq 0 \quad (8a)$$

$$P = P^T \geq 0, \quad (8b)$$

with $V(x) = x^T P x \geq 0$ defining a storage function. Note that if the realization (A, B, C) is minimal, then the inequality (8b) is strict, i.e. P is definite positive. In the following we will assume (A, B, C) being minimal.

Regarding the strict passivity, it is possible to show that a system $\Sigma(A, B, C, D)$ with (A, B, C) minimal, is strictly passive if the following LMI

$$\begin{pmatrix} A^T P + PA + \varepsilon P & PB - C^T \\ B^T P - C & -D - D^T \end{pmatrix} \leq 0 \quad (9a)$$

$$P = P^T > 0, \quad (9b)$$

is feasible for some $\varepsilon > 0$.

The passivity of a linear system $\Sigma(A, B, C, D)$ can be shown to be equivalent to the positive realness of the transfer matrix $G(s) = C(sI - A)^{-1}B + D$ [3].

III. FROM PWL FEEDBACK SYSTEMS TO AFFINE COMPLEMENTARITY SYSTEMS

Let us consider the dynamical part of the system in Figure 1:

$$\dot{x} = A_d x + B_d u \quad (10a)$$

$$y = C_d x + D_d u, \quad (10b)$$

with $x \in \mathbb{R}^n$, $u, y \in \mathbb{R}^m$ and (A_d, B_d, C_d) minimal.

We will consider static piecewise linear characteristics that can be described by the following LCP

$$\varphi = A_s \lambda + B_s z + \bar{g} \quad (11a)$$

$$w = C_s \lambda + D_s z + \bar{h} \quad (11b)$$

$$0 \leq w \perp z \geq 0, \quad (11c)$$

with $\varphi \in \mathbb{R}^m$, $\lambda \in \mathbb{R}^m$ and $z, w \in \mathbb{R}^q$. Such representation can be considered really general for describing set-valued piecewise linear mappings [12]. It is extremely useful also for describing the feedback structure of Figure 1. In that case $-\varphi$ is the input u of the dynamical linear system and λ is the output y of the system. So, putting all together,

$$\dot{x} = A_d x - B_d [A_s \lambda + B_s z + \bar{g}] \quad (12a)$$

$$\lambda \equiv y = C_d x - D_d [A_s \lambda + B_s z + \bar{g}] \quad (12b)$$

$$w = C_s \lambda + D_s z + \bar{h} \quad (12c)$$

$$0 \leq w \perp z \geq 0. \quad (12d)$$

By looking at the equation (12b), if the matrix $D_d A_s$ has no eigenvalues in -1 , the matrix $M \triangleq I + D_d A_s \in \mathbb{R}^{m \times m}$ is invertible and

$$\lambda = M^{-1} [C_d x - D_d B_s z - D_d \bar{g}]. \quad (13)$$

Now system (12) can be written as (4) with

$$A := A_d - B_d A_s M^{-1} C_d, \quad (14a)$$

$$B := B_d A_s M^{-1} D_d B_s - B_d B_s, \quad (14b)$$

$$C := C_s M^{-1} C_d, \quad (14c)$$

$$D := D_s - C_s M^{-1} D_d B_s, \quad (14d)$$

$$g := B_d [A_s M^{-1} D_d - I] \bar{g}, \quad (14e)$$

$$h := \bar{h} - C_s M^{-1} D_d \bar{g}. \quad (14f)$$

Note that being M singular, it means that the feedback structure has an algebraic loop not solvable and we get an ill-posed problem. Note that in the case $D_d > 0$ and $A_s \geq 0$, the matrix $M = (I + D_d A_s)$ is invertible (see [13]).

IV. WELL-POSEDNESS AND STABILITY

The following analysis refers to the existence of solutions and stability of the affine complementarity systems (4).

A. Well-posedness

Theorem 2: Consider an ACS (4) such that the system $\Sigma(A, B, C, D)$ is passive. Then, given an initial state $x(0) = x_0$, it exists an absolutely continuous solution $x(t)$ for almost every $t \geq 0$, if and only if the conditions

$$C x_0 + h \in \mathcal{Q}_D^* \quad (15)$$

$$h \in \mathcal{Q}_D^* + \text{im} C \quad (16)$$

hold.

Proof: See the authors' report [14]. ■

In the following we assume that an absolute continuous solution exists on the time interval $[0, \infty)$.

B. Equilibria

All equilibrium points $(\bar{x} \ \bar{z})^T$ satisfy the following relations:

$$0 = A\bar{x} + B\bar{z} + g \quad (17a)$$

$$\bar{w} = C\bar{x} + D\bar{z} + h \quad (17b)$$

$$0 \leq \bar{w} \perp \bar{z} \geq 0. \quad (17c)$$

It is clear that in the case the static gain $-CA^{-1}B + D$ is a P-matrix, there exists a unique solution of the LCP (17), and so there exists a unique equilibrium point $(\bar{x} \ \bar{z})^T$ of (4). The same occurs if $\Sigma(A, B, C, D)$ is strictly passive: in fact the transfer function $G(j\omega) = C(j\omega I - A)^{-1}B + D$ is positive definite for all ω , in particular for $\omega = 0$. It means that $-CA^{-1}B + D$ exists and is positive definite, thus it is a P-matrix.

C. Stability

We now analyze the stability of the equilibria of (4) under the hypothesis of passivity of $\Sigma(A, B, C, D)$. Let us rewrite (4) in terms of the variations $x_\delta = x - \bar{x}$ and $z_\delta = z - \bar{z}$:

$$\dot{x}_\delta = Ax_\delta + Bz_\delta \quad (18a)$$

$$w_\delta = Cx_\delta + Dz_\delta \quad (18b)$$

$$0 \leq w_\delta + \bar{w} = w \perp z = z_\delta + \bar{z} \geq 0. \quad (18c)$$

Since $\Sigma(A, B, C, D)$ is passive, there exists a quadratic storage function $V(x) = x^T P x > 0$ that is null only in the origin. We will show that $V(x_\delta) = x_\delta^T P x_\delta$ is a Lyapunov function for system (18). First of all we will prove the following lemma.

Lemma 1: Any trajectory $(x_\delta \ z_\delta)^T$ of system (18) will satisfy the constraint

$$z_\delta^T w_\delta = z_\delta^T C x_\delta + z_\delta^T D z_\delta \leq 0. \quad (19)$$

Proof:

$$\begin{aligned} z_\delta^T w_\delta &= (z - \bar{z})^T (w - \bar{w}) \\ &= z^T w - z^T \bar{w} - \bar{z}^T w + \bar{z}^T \bar{w} \\ &= -z^T \bar{w} - \bar{z}^T w \leq 0. \end{aligned} \quad (20)$$

By using the previous lemma, we can infer Lyapunov stability of the equilibria \bar{x} :

Theorem 3: Consider an ACS (4) such that $\Sigma(A, B, C, D)$ is passive. Then all equilibrium points \bar{x} are stable. Moreover, if $\Sigma(A, B, C, D)$ is strictly passive, the unique equilibrium point is globally exponentially stable.

Proof: By passivity of Σ , there exists a matrix $P = P^T > 0$ satisfying LMI (8a). Let us introduce the following quadratic function:

$$V(x_\delta) = x_\delta^T P x_\delta. \quad (21)$$

Note that this function is continuous in x_δ and it has no discontinuities on $[0, +\infty)$. It is a continuously differentiable function with respect to its domain \mathbb{R}^n and its time derivative is

$$\dot{V} = \left(\frac{\partial V(x_\delta)}{\partial x_\delta} \right)^T (Ax_\delta + Bz_\delta) \quad \text{a.e.} \quad (22)$$

except at isolated time instants where z_δ is discontinuous. By using LMI (8a), Lemma 1 and (18b), we have

$$\begin{aligned} \dot{V} &= x_\delta^T (A^T P + PA)x_\delta + x_\delta^T P B z_\delta + z_\delta^T B^T P x_\delta \\ &\leq x_\delta^T (A^T P + PA)x_\delta + x_\delta^T P B z_\delta + z_\delta^T B^T P x_\delta - 2z_\delta^T w_\delta \\ &= (x_\delta \ z_\delta)^T \begin{pmatrix} A^T P + PA & PB - C^T \\ B^T P - C & -D - D^T \end{pmatrix} \begin{pmatrix} x_\delta \\ z_\delta \end{pmatrix} \\ &\leq 0, \end{aligned} \quad (23)$$

from which follows the stability of all equilibria \bar{x} .

In the case $\Sigma(A, B, C, D)$ satisfies the strict passivity condition, by using LMI (9a) it is easy to show that

$$\dot{V} \leq -\varepsilon x_\delta^T P x_\delta < 0 \quad (24)$$

which implies the global exponential stability of the unique equilibrium \bar{x} . ■

V. PASSIVITY OF THE FEEDBACK INTERCONNECTION

As shown in Section IV, in order to study stability we need the passivity property related to the system $\Sigma(A, B, C, D)$ with respect to input-output variables z and w . Note that system Σ can be represented as in Figure 3 by assuming g and h to be zero. Under the hypothesis that Σ_d is passive we would like to investigate which conditions the representation (11) should satisfy in order to get the system Σ passive.

From well-known results on feedback interconnection of passive systems [3] it follows that the system with input $-B_s z$ and output y is strictly passive if Σ_d is passive and $A_s > 0$ or in the case Σ_d is strictly passive and $A_s \geq 0$.

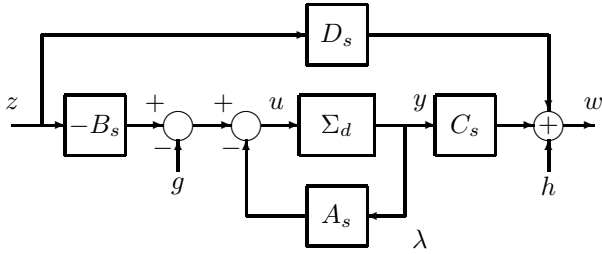

Fig. 3. Block diagram of the closed loop systems under consideration including the $\varphi(\lambda)$ characteristic representation.

Looking at the conditions that the piecewise linear characteristic $\varphi(\lambda)$ should satisfy in order to have $\Sigma(A, B, C, D)$ to be passive, we can prove the following

Theorem 4: If the dynamic system $\Sigma_d(A_d, B_d, C_d, D_d)$ is (strictly) passive and

$$Q_s = \begin{pmatrix} A_s & B_s \\ C_s & D_s \end{pmatrix} \geq 0 \quad (25)$$

then the system $\Sigma(A, B, C, D)$ is (strictly) passive. Moreover if (25) is verified then the function $\varphi(\lambda)$ is nondecreasing.

Proof: By definition (see Section III), passivity of Σ does not involve g and h . Therefore, assuming $g = 0$ and $h = 0$,

$$z^T w + \lambda^T \varphi = (\lambda^T \quad z^T) \begin{pmatrix} \varphi \\ w \end{pmatrix} = (\lambda^T \quad z^T) Q_s \begin{pmatrix} \lambda \\ z \end{pmatrix}. \quad (26)$$

Then, by using (25) and (strict) passivity of Σ_d , one obtains:

$$\begin{aligned} z^T w &= (\lambda^T \quad z^T) Q_s \begin{pmatrix} \lambda \\ z \end{pmatrix} - \lambda^T \varphi \\ &= (\lambda^T \quad z^T) Q_s \begin{pmatrix} \lambda \\ z \end{pmatrix} + y^T u \geq y^T u \\ &\geq \dot{V}(x) (+\psi(x)), \end{aligned} \quad (27)$$

where $V(x)$ is the storage function of system Σ_d (and $\psi(x)$ is a positive definite function). Inequality (27) implies the (strict) passivity of the system Σ (see [3]).

Assume now that (25) is verified. By considering any two points of the characteristic (λ_1, φ_1) and (λ_2, φ_2) , from (11)

one obtains:

$$\begin{aligned} &(\lambda_1 - \lambda_2)^T (\varphi_1 - \varphi_2) + (z_1 - z_2)^T (w_1 - w_2) \\ &= (\lambda_1^T - \lambda_2^T \quad z_1^T - z_2^T) Q_s \begin{pmatrix} \lambda_1 - \lambda_2 \\ z_1 - z_2 \end{pmatrix} \geq 0 \\ &\forall (\lambda_i, \varphi_i := \varphi(\lambda_i)). \end{aligned} \quad (28)$$

Using (28) and by recalling Lemma 1,

$$(\lambda_1 - \lambda_2)^T (\varphi_1 - \varphi_2) \geq -(z_1 - z_2)^T (w_1 - w_2) \geq 0, \quad (29)$$

which implies nondecreasing monotonicity of $\varphi(\lambda)$. ■

The previous theorem extends the results on passivity reported in [4]. Indeed, by using circuit theory arguments it will be shown in Section VI that for any nondecreasing $\varphi(\lambda)$ it always exist a representation (25) for which $Q_s \geq 0$.

VI. COMPLEMENTARITY REPRESENTATIONS OF PWL CHARACTERISTICS

As shown above, the affine complementarity representation of the piecewise linear characteristic influences the passivity of $\Sigma(A, B, C, D)$ on which well-posedness and stability results are obtained. Thus, it is important to analyze the different possible complementarity representations of the characteristic, since there is no unique representation.

A. Breaking points models

Let us consider a generic piecewise linear characteristic with m breaking points. A possible complementarity repre-

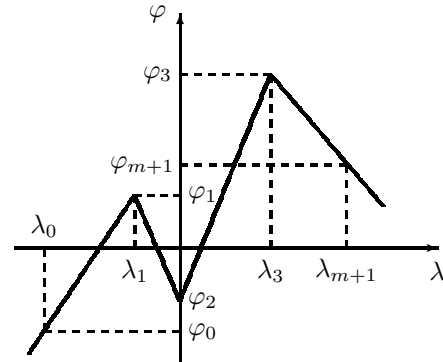

Fig. 4. Piecewise linear characteristic with $m = 3$ breaking points.

sentation of the characteristic reported in Figure 4 can be obtained by imposing [15]

$$\begin{aligned} \begin{pmatrix} \varphi \\ \lambda \end{pmatrix} &= \begin{pmatrix} \varphi_1 \\ \lambda_1 \end{pmatrix} + \begin{pmatrix} \varphi_0 \\ \lambda_0 \end{pmatrix} \mu_1^- + \begin{pmatrix} \varphi_2 - \varphi_1 \\ \lambda_2 - \lambda_1 \end{pmatrix} \mu_1^+ \\ &+ \sum_{k=2}^{m-1} \begin{pmatrix} \varphi_{k+1} - 2\varphi_k + \varphi_{k-1} \\ \lambda_{k+1} - 2\lambda_k + \lambda_{k-1} \end{pmatrix} \mu_k^+ \\ &+ \begin{pmatrix} \varphi_{m+1} - \varphi_m + \varphi_{m-1} \\ \lambda_{m+1} - \lambda_m + \lambda_{m-1} \end{pmatrix} \mu_m^+ \end{aligned} \quad (30)$$

$$\mu_j^+ - \mu_j^- = \mu_1^+ - \mu_1^- - (j-1) \quad (31)$$

with $\mu_j^+ \geq 0$, $\mu_j^- \geq 0$ and $\mu_j^+ \cdot \mu_j^- = 0$ for $j = 1, \dots, m$. The parameters (λ_0, φ_0) and $(\lambda_{m+1}, \varphi_{m+1})$ must be chosen as the coordinates of points belonging to the initial and final

direction of the characteristic, respectively. By considering a scalar characteristic, a possible complementarity model in the form (11) can be obtained by choosing, for instance, $z_j = \mu_j^+$, $w_j = \mu_j^-$ for $j = 1, \dots, m$ and by computing $w_1 = \mu_1^-$ from the second component of (30).

B. Equivalent circuit models

From circuit theory it follows that any piecewise linear characteristic can be represented by means of an equivalent circuit in which there are only resistors, independent voltage and current sources and ideal diodes [8], [16]. Let us first consider the typical idealized voltage-current characteristic of a diode. Let v_D the voltage across the diode, and i_D the current through the diode. The behavior of a diode can then be described by

$$(-v_D = 0 \wedge i_D \geq 0) \vee (-v_D \leq 0 \wedge i_D = 0). \quad (32)$$

The relation (32) can be rewritten as a complementarity relation by choosing $z = -v_D$ and $w = i_D$ or conversely. By exploiting the ideal diode characteristic one can construct any piecewise linear characteristic assuming that φ and λ are current and voltage at the terminals of a suitable equivalent circuit. In the circuit theory framework there exist algorithms for constructing such m -port equivalent circuit starting from the (possibly multivariable) voltage-current characteristic to be represented [16], [17]. Figure 4 together with Figure 5 and Table I report a simple example. Once the equivalent circuit has been obtained one can simply construct the model (11) by using the Kirchhoff rules (that give matrices A_s , B_s , C_s and D_s) and the complementarity conditions on the voltage and currents of the ideal diodes, while \bar{g} and \bar{h} are related to the independent voltage and current sources in the equivalent circuit.

By using some circuit theory results [8], it can be shown that any nondecreasing characteristic can be represented by means of circuits with diodes, independent sources and only positive resistors. Therefore by using the equivalent circuit representation of $\varphi(\lambda)$ it is shown that for any nondecreasing PWL characteristic it always exists a representation (11) with $Q_s \geq 0$. In fact, from the model (11) and by the circuit interpretation, it follows that the quantity $\lambda^T \varphi + z^T w$ represents the power furnished to the circuit obtained by putting to zero all sources ($\bar{g} = 0$ and $\bar{h} = 0$), i.e. voltage sources considered as short circuits and current sources considered as open circuits. Since the resulting circuit contains only positive resistors, the power furnished to the circuit must be non negative and from (26) one can conclude that $Q_s \geq 0$.

Thus, by using Theorem 4 one can conclude passivity of the closed loop system when Σ_d is passive and $\varphi(\lambda)$ is any nondecreasing possibly set-valued function.

VII. APPLICATIONS

We first consider the case of a non passive Σ_d system with a static characteristic $\varphi(\lambda)$ that is nondecreasing and set-valued. Let Σ_d be the non passive linear system

$$\dot{x} = x + u, \quad (33)$$

$$y = x, \quad (34)$$

saturation	$\varphi_0 = \varphi_1 = -1$ $\varphi_2 = \varphi_3 = +1$ $-\lambda_1 = \lambda_2 = +1$ $\lambda_0 < -1, \lambda_3 > +1$	$V = 1, R_1 = 1$ $I = 2, R_2 = +\infty$ $I_b = 1, R_b = +\infty$
step	$\varphi_0 = \varphi_1 = 0$ $\varphi_2 = \varphi_3 = +1$ $\lambda_1 = \lambda_2 = 0$ $\lambda_0 < 0, \lambda_3 > 0$	$V = 0, R_1 = 0$ $I = 1, R_2 = +\infty$ $I_b = 0, R_b = +\infty$
$\max(\lambda - \bar{\lambda}, 0)$	$\varphi_0 = \varphi_1 = \varphi_2 = 0$ $\lambda_1 = \lambda_2 = \bar{\lambda}$ $\varphi_3 > 0$ $\lambda_0 < \bar{\lambda}, \lambda_3 > \bar{\lambda}$	$V = -\bar{\lambda}, R_1 = 0$ $R_2 = 0$ $I_b = 0, R_b = +\infty$

TABLE I

SOME CHARACTERISTICS BELONGING TO THE CLASS REPORTED IN FIGURE 4 WITH THE CORRESPONDING CIRCUIT PARAMETERS OF FIGURE 5.

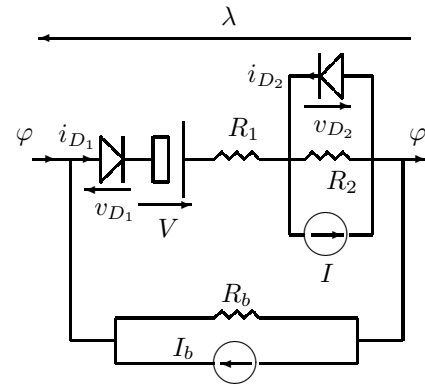

Fig. 5. Equivalent circuit corresponding to the piecewise linear characteristic reported in Table I. The circuit parameters depend on φ_i and λ_i .

with $u = -\varphi$, $\lambda = y$ and the set-valued function $\varphi(\lambda)$ reported on the left of Figure 6. By choosing as λ_i and φ_i the points indicated in the figure, the representation (30)-(31) leads to the following matrices of the model (11):

$$A_s = 2, \quad B_s = \begin{pmatrix} 1 & 0 \end{pmatrix}, \quad \bar{g} = 0, \quad (35)$$

$$C_s = \begin{pmatrix} -1 \\ -1 \end{pmatrix}, \quad D_s = \begin{pmatrix} 0 & 0.5 \\ -1 & 1.5 \end{pmatrix}, \quad \bar{h} = \begin{pmatrix} 0 \\ 1 \end{pmatrix}. \quad (36)$$

An equivalent circuit representation of the characteristic can be obtained by considering the circuit of Figure 5 with the same values reported in the second row of Table I (step function) with $R_b = 1/2$ instead of $+\infty$. Choosing as complementarity variables $z_1 = i_{D1}$, $w_1 = -v_{D1}$, $z_2 = -v_{D2}$ and $w_2 = i_{D2}$ the resulting complementarity representation (11) has the same A_s , B_s , \bar{g} and \bar{h} of the previous model and

$$C_s = \begin{pmatrix} -1 \\ 0 \end{pmatrix}, \quad D_s = \begin{pmatrix} 0 & 1 \\ -1 & 0 \end{pmatrix}. \quad (37)$$

It is straightforward to verify that in this case $Q_s \geq 0$. Our aim is to study passivity of the closed loop system Σ by using both the two different LCP representations of the PWL feedback characteristic. Note that results in [4] cannot be applied since the linear dynamical system is not passive. The closed loop system in the case of the first LCP representation

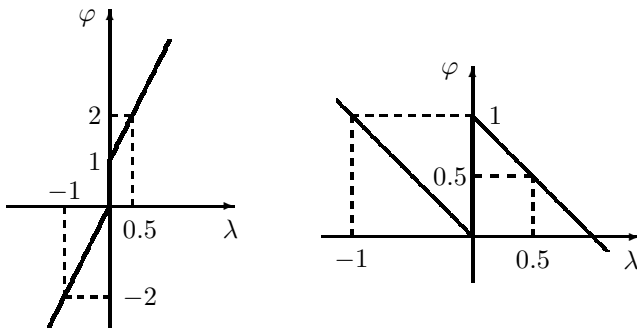

Fig. 6. Piecewise linear set-valued functions.

has the following matrices:

$$A = -1, \quad B = \begin{pmatrix} -1 & 0 \end{pmatrix}, \quad g = 0, \quad h = \begin{pmatrix} 0 \end{pmatrix} \quad (38)$$

$$C = \begin{pmatrix} -1 \\ -1 \end{pmatrix}, \quad D = \begin{pmatrix} 0 & 0.5 \\ -1 & 1.5 \end{pmatrix}. \quad (39)$$

Such matrices give rise to a non passive $\Sigma(A, B, C, D)$ while, in the case of the equivalent circuit LCP representation, the closed loop system can be represented in the complementarity form (4) with the matrices in (38) and

$$C = \begin{pmatrix} -1 \\ 0 \end{pmatrix}, \quad D = \begin{pmatrix} 0 & 1 \\ -1 & 0 \end{pmatrix}, \quad (40)$$

which give a strictly passive Σ as it can be verified through the LMI (9a) with $P = 1$. Therefore, using passivity (see [14]) one can conclude existence and uniqueness of the solution and, from Theorem 3, stability of the closed loop system.

Although we could not apply Theorem 4 since Σ_d was not passive, we were able to infer well-posedness and stability because by using circuit representation, Σ was passive. This example shows how it is important to choose a “good” LCP representation for the static characteristic. This consideration can be extended also for studying systems with static characteristics that are not nondecreasing. Consider as Σ_d

$$\dot{x} = -2x + u, \quad (41)$$

$$y = x. \quad (42)$$

The closed loop system obtained with $u = -\varphi$, $\lambda = y$ and the set-valued function $\varphi(\lambda)$ reported on the right of Figure 6, can be put in the complementarity form (4) by using both the breaking point approach and the equivalent circuit method for modelling the piecewise linear feedback. In the first case the matrices of the representation (4) are (38) and (39) and thus we do not have passivity. Still, if we use the equivalent circuit representation (circuit corresponding to the step function with $R_b = -1$ instead of $+\infty$), we get well-posedness and stability (we have matrices (38) and (40)).

VIII. CONCLUSIONS

The complementarity framework has been used to prove existence of absolute continuous solutions and stability of the equilibria for linear time invariant systems connected

in feedback through a piecewise linear static mapping. It is shown that the way how the feedback characteristic is modelled plays an important role for the passivity of the closed loop system. Using equivalent circuit representations, a novel approach for constructing a model of any piecewise linear characteristic in the complementarity framework is proposed. The circuit representation is useful to obtain passivity of the closed loop system when the feedback consists of any nondecreasing possibly set-valued characteristic.

REFERENCES

- [1] A.F. Filippov, *Differential Equations with Discontinuous Righthand Sides*, Kluwer Academic Publishers, 1988.
- [2] A. Bacciotti and L. Rosier, *Liapunov Functions and stability in control Theory*, Springer-Verlag, second edition, 2005.
- [3] H.K. Khalil, *Nonlinear Systems*, Prentice Hall, Upper Saddle River, New Jersey, USA, third edition, 2002.
- [4] B. Brogliato, “Absolute stability and the Lagrange-Dirichlet theorem with monotone multivalued mappings”, *Systems and Control Letters*, vol. 51, pp. 343–353, 2004.
- [5] M.K. Çamlıbel, W.P.M.H. Heemels, and J.M. Schumacher, “On linear passive complementarity systems”, special issue ‘Dissipativity of Dynamical Systems: Applications in Control’ (dedicated to V.M. Popov) of *European Journal of Control*, vol. 8, no. 3, pp. 220–237, 2002.
- [6] A.J. van der Schaft and J.M. Schumacher, “Complementarity modelling of hybrid systems”, *IEEE Transactions on Automatic Control*, vol. 43, no. 4, pp. 483–490, 1998.
- [7] W.P.M.H. Heemels and B. Brogliato, “The complementarity class of hybrid dynamical systems”, *European Journal of Control*, vol. 9, no. 2-3, pp. 322–360, 2003.
- [8] L.O. Chua, “Nonlinear circuits”, *IEEE Transactions on Circuits and Systems*, vol. 31, no. 1, pp. 69–87, 1984.
- [9] R.W. Cottle, J.-S. Pang, and R.E. Stone, *The Linear Complementarity Problem*, Academic Press, Boston, 1992.
- [10] M.K. Çamlıbel, *Complementarity Methods in the Analysis of Piecewise Linear Dynamical Systems*, PhD thesis, Dissertation Series of Center for Economic Research, Tilburg University, The Netherlands, 2001, (ISBN: 90 5668 079 X).
- [11] W.P.M.H. Heemels, M.K. Çamlıbel, and J.M. Schumacher, “On the dynamic analysis of piecewise-linear networks”, *IEEE Transactions on Circuits and Systems, Part I: Fundamental Theory and Applications*, vol. 49, no. 3, pp. 315–327, March 2002.
- [12] D.M.W. Leenaerts and W.M.G. van Bokhoven, *Piecewise Linear Modelling and Analysis*, Kluwer Academic Publishers, Dordrecht, The Netherlands, 1998.
- [13] W.M. Haddad and D.S. Bernstein, “Robust stabilization with positive real uncertainty: Beyond the small gain theorem”, in *Proc. of the 29th IEEE Conference on Decision and Control*, Honolulu, Hawaii (USA), December 1990, IEEE, pp. 2054–2059.
- [14] M.K. Çamlıbel, L. Iannelli, and F. Vasca, “Passivity and complementarity”, 2005, technical report available at <http://www.grace.ing.unisannio.it/publication/352>.
- [15] L. Vandenberghe, B.L. De Moor, and J. Vandewalle, “The generalized linear complementarity problem applied to the complete analysis of resistive piecewise-linear circuits”, *IEEE Transactions on Circuits and Systems*, vol. 36, no. 11, pp. 1382–1391, 1989.
- [16] T.E. Stern, “Piecewise-linear network theory”, Tech. Rep. 315, MIT Research Laboratory of Electronics, Cambridge, Massachusetts, USA, June 1956.
- [17] R.W. Donaldson, “Realization of piecewise-linear driving-point and transfer characteristics by RDS network”, *IEEE Transactions on Circuit Theory*, vol. 14, no. 1, pp. 52–56, 1967.