

University of Groningen

Operational performance of two-stage food production systems

Akkerman, R.

IMPORTANT NOTE: You are advised to consult the publisher's version (publisher's PDF) if you wish to cite from it. Please check the document version below.

Document Version

Publisher's PDF, also known as Version of record

Publication date:

2007

[Link to publication in University of Groningen/UMCG research database](#)

Citation for published version (APA):

Akkerman, R. (2007). *Operational performance of two-stage food production systems: process interactions and capacitated storage*. [Thesis fully internal (DIV), University of Groningen]. s.n.

Copyright

Other than for strictly personal use, it is not permitted to download or to forward/distribute the text or part of it without the consent of the author(s) and/or copyright holder(s), unless the work is under an open content license (like Creative Commons).

The publication may also be distributed here under the terms of Article 25fa of the Dutch Copyright Act, indicated by the "Taverne" license. More information can be found on the University of Groningen website: <https://www.rug.nl/library/open-access/self-archiving-pure/taverne-amendment>.

Take-down policy

If you believe that this document breaches copyright please contact us providing details, and we will remove access to the work immediately and investigate your claim.

Downloaded from the University of Groningen/UMCG research database (Pure): <http://www.rug.nl/research/portal>. For technical reasons the number of authors shown on this cover page is limited to 10 maximum.

CHAPTER 2

Context-Based Scheduling

Published as:

R. AKKERMAN AND D.P. VAN DONK (2006), *Analysing scheduling in the food-processing industry: Structure and tasks*, Cognition, Technology & Work, accepted for publication.

Abstract

Production scheduling has been widely studied in several research areas, resulting in a large number of methods, prescriptions, and approaches. However, the impact on scheduling practice seems relatively low. This is also the case in the food-processing industry, where industry-specific characteristics induce specific and complex scheduling problems.

Based on ideas about decomposition of the scheduling task and the production process, we develop an analysis methodology for scheduling problems in food processing. This combines an analysis of structural (technological) elements of the production process with an analysis of the tasks of the scheduler. This helps to understand, describe, and structure scheduling problems in food processing, and forms a basis for improving scheduling and applying methods developed in literature. It also helps in evaluating the organisational structures and information flows related to scheduling.

2.1 Introduction

Production scheduling is a widely studied subject in different research areas such as production and operations management, operations research (OR), artificial intelligence (AI), and cognitive sciences (CS). These research areas contain elements like modelling, analysing, and simulating the decision making process involved. It has focused on topics like algorithmic approaches, organizational problems, and information systems analysis.

In spite of all this research into scheduling, it seems to have had relatively little impact on production practice, where the use of scheduling systems and

methods remains rare (McKay *et al.*, 2002). This is also the case in the food-processing industry, where industry-specific characteristics make scheduling a hard, but important, issue (e.g., Jakeman, 1994). In this paper, we focus on food processing, being a significant part of the total industry that has received relatively little attention in scheduling research.

The lack of use in practice is, according to McKay *et al.* (2002), mainly because of the myopic nature of scheduling research. It mostly deals with simplified situations or only parts of a situation. Moreover, according to Crawford *et al.* (1999), scheduling is difficult to study because it can only be thoroughly investigated in the environment in which it is normally found: a complex, dynamic manufacturing environment. This also emphasizes the need for industry-specific instruments for scheduling. In our view, the complexity is mostly due to the fact that scheduling is often an unstructured issue, where the basic scheduling problems are interconnected with problems around organizational responsibilities and information flows.

Furthermore, the scheduling environment in food is complicated due to reasons like changing product mixes and incremental changes to the production system. Together with the unstructured nature of scheduling, this results in very difficult to analyse situations in practice. For this reason, we need structured methodologies to analyse scheduling problems linked to specific circumstances.

To improve the understanding of scheduling problems, we believe a context-based analysis is useful. The context of scheduling problems can be interpreted in many ways. In this paper, we focus on two main parts of context; relating to the specific characteristics of the production process involved and relating to the tasks of the scheduler and others involved.

To some extent, the decision-making tasks have some generic aspects, although their relevance might be different in various situations. However, we submit that the configuration of characteristic elements of a production process are less generic and often strongly industry-specific and induce typical scheduling problems.

The aim of this paper is to develop an analysis methodology that combines insights from two research areas. First, the decision process of the schedulers, and secondly, the characteristics of the production process. So far, the combination of these two areas has been relatively ignored in the literature, especially concerning the food-processing industry. We aim to provide a conceptual contribution, grounded in empirical findings, that adds to the discussion on bridging the gap between scheduling theory and scheduling

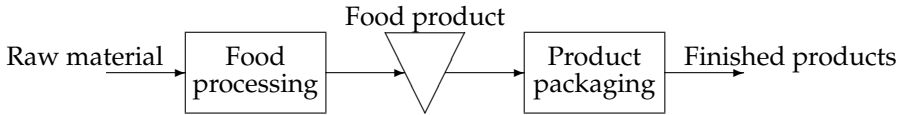

Figure 2.1. Typical two-stage food production process.

practice.

The paper is organised as follows. We first show the specific nature of food processing in section 2.2. Then, in section 2.3, we show that current approaches to scheduling fail to address the specific problems. Section 2.4 elaborates upon different ways to decompose scheduling problems: one based on the production process characteristics and one based on tasks. Section 2.5 then develops the context-based analysis methodology using and combining two decomposition methods. Finally, in section 2.6, our conclusions and some thoughts on further research topics are presented.

2.2 The food-processing industry

The food-processing industry can be considered as a part of the process industries, which is defined as ‘firms that add value by mixing, separating, forming or chemical reactions’ (Cox and Blackstone, 2002). In food processing, these operations are applied on agricultural raw material to obtain food products. The processing of this raw material can be continuous or in batches. When the latter is the case, one often refers to semi-process industries (Van Rijn and Schyns, 1993). In general, the production process can be divided into two stages: processing of raw materials into intermediate products and packaging of food products (see Figure 2.1).

A number of studies (e.g., Meulenberg and Viaene, 1998; Nakhla, 1995) show the increasing need for flexibility, due to growing logistical demands as the result of the change in the market conditions for food-processing companies. Other changes are a tendency towards more diversity and the growth of unique products for certain customers, such as special offers (e.g., 10% extra, different packaging) along with specific orders for export. Certain products are demanded in limited quantities or with large gaps between orders. A quick response to changes necessitates proper scheduling and scheduling support (e.g., Jakeman, 1994).

Problems in scheduling in the food-processing industry are specifically induced by the characteristics of the processes. The food-processing industry

Table 2.1. Case studies arranged by industry type.

Type	Industries	Number of characteristics	
		Average	Range
1	Flour, Meat products, Grain processing	6.5	2–11
2	Pastry, Dairy (fromage frais), Ice cream, Snack food	4	1–7
3	Dairy (cheese, yogurt), Beer, Alimentary preserves, Freeze drying, Animal fodder	5.4	4–7
Overall mean and range		5.2	1–11

Legend:
 Type 1 — Raw materials are processed into intermediate products
 Type 2 — Intermediate products are processed into end products
 Type 3 — Raw materials are processed into end products

Derived from: Claassen and Van Beek (1993), Dov (1992), Fairfield and Kingsman (1993), Houghton and Portugal (1997), Jakeman (1994), Macchietto (1996), Moreno-Lizaranzu *et al.* (2001), Nakhla (1995), Randhawa *et al.* (1994), Roosma and Claassen (1996), Sivula (1990), Tadei *et al.* (1995), Van Donk (2001), Van Donk and Van Dam (1996), and 3 unpublished cases (flour, dairy, and pastry).

has a lot in common with other (semi-) process industries. Fransoo and Rutten (1994) and Van Rijn and Schyns (1993) describe typical characteristics for the (semi-) process industries.

Our compilation of food-processing characteristics is based on an analysis of case studies published in journals, conference proceedings, and books in the period from 1990 to 2001, complemented with the findings from recently conducted case studies by the authors. These studies involved factory tours and discussions with production managers and schedulers. The 17 cases are representative for the variety of the whole food-processing industry and are divided over all three types of processes distinguished in a report by Moret Ernst & Young Management Consultants (1997). Therefore, the sample satisfies the requirements of theoretical sampling (see Eisenhardt, 1989). Table 2.1 shows an overview of the case studies, as well as the average number of characteristics found.

Table 2.2 shows what characteristics are encountered in food-processing industry and how often they appear. We discuss shortly the effects of some characteristics on scheduling by taking two typical examples: setup times and perishability.

First, (sequence-dependent) setup times are often induced by numerous different tastes, colours, or concentrations (*e.g.*, Dov, 1992; Nakhla, 1995). The multitude of end products in the divergent product structure in most food-processing companies even aggravates the impact of setup time on scheduling. For example, Claassen and Van Beek (1993) describe a dairy company with about 2,500 end products, which are based on a few raw materials. In the production of such a wide variety of products, setup activities are frequently

Table 2.2. Compilation of product and production characteristics of the food-processing industry (including the number of times encountered in a case study).

Times encountered	Characteristics
> 5 ×	(Sequence dependent) set-up times Connectivity (no or limited intermediate storage allowed) Divergent product structure Perishable goods Shared resources Variable demand for end-products
5 ×	Limited capacity of machines and labor Variable yields/duration of process
4 ×	Varying position of customer order decoupling point
3 ×	Breakdowns cause disrupted schedules Only one line for job Production rate determined by capacity Scheduling by increasing flavor or color Variable time/quantity/price of delivery
2 ×	Combination of batch and continuous processes Production runs range from minutes to days Same operation, different productivity rates
1 ×	A lot of unit operations High quality demands Processing stage not labor intensive Ongoing innovation Partly homogeneous products Production of by-products

See Table 2.1 for sources.

encountered. A major problem in scheduling is to restrict the effect on capacity of these setups, while maintaining due-dates and inventory levels.

Secondly, perishability of (intermediate) products also has a significant impact on the production process; it has consequences for numerous production decisions like sequencing and stocking. Limited shelf life induces make-to-order production, which makes it harder to schedule production. [Macchietto \(1996\)](#) states that the perishability dictates segregation into batches and makes production scheduling more difficult. In food-processing companies, perishability is also a major topic concerning the high quality demands that have to be coped with. Another consequence of the perishability (of intermediate products) is that production stages often cannot be decoupled, and therefore have to be scheduled as one process (*e.g.*, [Van Donk, 2001](#)).

For most of the cases, several characteristics are present (see the average number in Table 2.1). As shown above, each of the characteristics in Table 2.2 induces its own scheduling problem. It mostly happens that several characteristics—and their corresponding scheduling problems—are present in a single case. As explained, dealing with sequence-dependent setup times

can be complicated in itself. However, this will be even more complicated if several connected processes (with no or limited intermediate storage allowed) have sequence-dependent setup times. For instance, in dairy industries it can happen that the processing stage has to be sequenced from low to high concentrations of a certain additive, while in the packaging stage the preferred sequences are based on package size. Furthermore, sequence-dependent setup times are often accompanied with perishability, a divergent product structure, or connectivity. Interactions between these characteristics complicate the scheduling problem even more. Table 2.1 showed that, on average, a scheduler has about five characteristics to deal with. In one case, it were even eleven characteristics. This number of characteristics and their interactions are the reason for the complexity of scheduling in food processing. To some extent, we think that the type of characteristics and especially their combinations and interactions are typical for the food processing industry, but other industries will have other combinations of (probably also interacting) characteristics.

2.3 A review of scheduling approaches

In this section, we will first give some general observations and then discuss some specific applications that are of specific interest to the food-processing industry.

Scheduling is generally defined as the allocation of resources over time to perform a collection of tasks (Baker, 1974). It has been studied extensively, and numerous approaches to scheduling problems have been published over the last 50 years.

One of the main fields in scheduling research is operations research (OR). This resulted in a multitude of techniques, algorithms, and heuristics (see Kondili *et al.*, 1993; Morton and Pentico, 1993). Because of the advances in the computer sciences, these techniques have found their way to commercial software packages. However, the functionality provided in these packages is not always used (LaForge and Craighead, 2000). More than twenty years ago, Graves (1981) noted that the theory was not sufficiently developed to be applicable. This ‘gap’ between theory and practice still exists, according to McKay *et al.* (2002). However, in most cases, heuristic methods can find feasible solutions to scheduling problems, if they can be formulated mathematically. Finding an optimal solution normally requires a lot more time, which is not always possible. Nevertheless, the results in this area are power-

ful, but only if it is possible to work with structured, well-defined problems or if simplified scheduling problems can be constructed. The major problem is that quite a number of real-life problems cannot easily be formulated as a mathematical scheduling problem.

Another approach to scheduling is artificial intelligence (AI), which originates from the cognitive sciences. AI has its base in the work by [Newell and Simon \(1972\)](#). They view the scheduler's task as a cognitive process of understanding and recognising situations and the choices for appropriate measures. In this research area, the emphasis is on the observation and description of decision-making processes. It has influences from psychology and also researches other decision-making processes like playing chess (*e.g.*, [Olson and Biolsi, 1991](#)). Formalising and simulating these various decision-making processes caught much attention. Numerous methods were developed, such as constraint satisfaction, expert systems, and genetic algorithms (*e.g.*, [Fox, 1990](#); [Metaxiotis et al., 2002](#); [Kent and Steward, 2000](#)). The original connection of AI with human cognitive processes has disappeared over time. Consequently, AI looks very similar to OR, and seems to suffer from the same 'gap' between theory and practice. [Kempf et al. \(1991\)](#) note that the use of scheduling systems developed in the field of AI is often not continued after the end of the research project. Moreover, according to [Smith \(1992\)](#), AI techniques are less useful in more complex scheduling problems.

Due to the lack of practical use of techniques from previously mentioned research areas, another area emerged in the field of cognitive sciences (CS), which returned to the original research approach of [Newell and Simon \(1972\)](#), where the focus is on the task of the scheduler (see also [Ericsson and Simon, 1984](#)). In these so-called task-oriented approaches, the main idea is that decision support must be based on the way the *scheduler* assigns the entities (machines, orders, operators, etc.), instead from mere assignment problems of entities. Decision support has to correspond to the different steps taken by the scheduler. Research in this area resulted in, for instance, the model for human scheduling by [Sanderson \(1991\)](#), the redesign of a scheduling task for decision support purposes ([Wiers, 1997](#)), the development of a scheduling framework based on the underlying structure of the scheduling task ([Van Wezel et al., 1996](#)), and the development of a decision support system based on planning subtasks and data manipulation tasks ([McKay and Wiers, 2003a](#)).

Another good example of a task-oriented approach can be found in [McKay et al. \(1995\)](#). They describe the decision rules of a scheduler in a printed circuit board factory, using techniques like protocol analysis. The au-

thors describe the decision process of the scheduler as neither official policy nor based on traditional methods of planning and scheduling. The scheduler uses information not normally used in analytical models, such as ‘the attention of people from the third shift during the last training session’. The main question asked by McKay *et al.* is whether the scheduling decisions and the information they are based on can be included in software or algorithms. They conclude that part of the decision process could be encoded, but also that a significant part cannot be encoded using current methods. What appears to be ‘common sense’ to the scheduler is sometimes very hard to incorporate in models or algorithms.

A drawback of the task-oriented approaches is that its focus is on analyzing, modelling and supporting the existing scheduling tasks as performed by the scheduler, but less on adapting and improving the scheduling (Van Wezel and Jorna, 2001). Another interesting, much debated, but unresolved issue is what portion of the task is suitable for computerisation, and what should be left to human control (McKay *et al.*, 2002). As a consequence, the human factor in planning and scheduling is an upcoming and promising research topic (*e.g.*, MacCarthy and Wilson, 2001).

Several of the specific characteristics of the food processing industries are dealt with in the literature, for instance, random yields (*e.g.*, Yano and Lee, 1995), set-up times (*e.g.*, Vanderbeck, 1998), or perishability (*e.g.*, Gupta and Karimi, 2003). But as was stated in section 2.2, one often has to deal with several characteristics at the same time, which complicates the scheduling problem considerably. This has often been ignored in the literature. Variability in yields and uncertainty in processing times are other relevant characteristics that are relatively ignored.

To conclude, most OR and AI research focuses on simplified situations or simplified parts of the total scheduling problem and this results in techniques that are often not used in practice. Moreover, the OR/AI approaches mostly don’t take into account the human aspect of scheduling. Research in the CS field focuses on the decision process and tasks of the scheduler, but little attention is paid to the characteristics of the production process to be scheduled.

So both approaches seem to be too generic to be valuable for improving real-life complex scheduling problems as those in food processing. We believe that scheduling methods should be based on both production system characteristics and the schedulers’ task, and that this combination is the key to a successful approach to scheduling problems. In the next section we develop the building blocks for a combined approach.

2.4 Decomposition of scheduling problems

Decomposition is a common technique to deal with complex problems. [Ovacik and Uzsoy \(1997\)](#) state that decomposition methods attempt to develop solutions to complex problems by decomposing them into a number of smaller subproblems, which are more tractable and easier to understand (see also [Simon, 1981](#)). [Ovacik and Uzsoy \(1997\)](#) give two more arguments in favour of decomposition. First, not all parts of a problem are always equally important. By addressing subproblems in order of criticality, a solution of good quality can be found (see also [Goldratt, 1986](#)). Second, different operations to be scheduled can have different characteristics. This specific structure can often be used to gain computational advantages if used as a basis for decomposition methods.

After solving the individual subproblems, the solutions are integrated to form a solution for the initial problem. The combined solutions from the subproblems might not always be the same as a single solution for the whole problem. However, if the decomposition is performed carefully, the combined solutions can be a good approximation of the single solution, while being a lot easier to achieve. [Bertrand et al. \(1990\)](#) call this a decrease of decision freedom, which is countered by a reduction of complexity, which in turn improves the decision making.

[Crawford et al. \(1999\)](#) and [Rolo and Cabrera \(2000\)](#) state that the context is important in planning and scheduling. We state that this scheduling context can be understood in two ways; as the structure of the production process and as the decision process of the people involved in the creation of the schedule. The importance of product and production characteristics has been shown in section 2.2. The task-oriented approach emphasises that scheduling is not just an isolated decision-making task, but rather a number of connected tasks influenced by the organisation and its characteristics. This organizational context concerns elements such as the number of people involved in planning and scheduling and the use of information technology.

In the development of a context-based approach, we therefore use two different types of decomposition: a structural decomposition and a task decomposition.

2.4.1 Structural decomposition

In this paper, we interpret structural elements to be the characteristics of the production process, in terms of products, processing steps, storage possibili-

ties, and transportation methods between stages. These elements can be used in the development of a structural decomposition. The inclusion of structural decompositions in our context-based approach to scheduling is based on the recognition that scheduling systems should better reflect realities of the plant (LaForge and Craighead, 2000). Therefore, one needs to have a thorough understanding of the structure of the production process and its specific characteristics.

Structural decomposition approaches

In the literature, several useful contributions to the structural approach can be found. The first two contributions we discuss are applicable in any industry type. The presence of industry-specific characteristics induces the need for specific tools to describe the situation. Therefore, the third and fourth contribution we present are especially useful in the food-processing industry.

First, an important concept in this field is the decoupling point, as introduced by Hoekstra and Romme (1992). This concept identifies the point in the production process where the production becomes order-driven. The production process is often scheduled in a different way before and after this decoupling point. Often, it is forecast-driven before the decoupling point and order-driven after the decoupling point. This results in different scheduling methods, but also different requirements on information flows and organizational responsibilities. Van Donk (2001) discusses a framework that adapts the decoupling point concept for use in the food-processing industry. Soman *et al.* (2004) also use this concept in the development of their hierarchical planning and scheduling framework for food processing.

A second contribution is the distinction between goods flow control and production unit control, introduced by Bertrand *et al.* (1990). A production unit is a part of the production system that over a short term is self-contained. It is responsible for the production of certain (intermediate) products from certain materials or components. Production unit control concerns the control activities with a local scope (within production units), such as sequencing rules. Goods flow control concerns control activities with a global scope; between production units and between production and sales. An example is the release of work orders to the production units. This approach focuses on the control structure, not on the application of mathematical techniques. This resulted from the strong belief that the design of production and inventory control systems requires a strong organizational viewpoint. In food processing, a production unit can be a single machine, but also a complete processing

or packaging stage. The goods flow control becomes especially relevant in situations where batch processes and continuous processes are both present, which is quite common in food processing.

Third, we mention the process flow scheduling approach by [Taylor and Bolander \(1994\)](#), which is a constraint-oriented scheduling system, based on a thorough analysis of the production system. It uses a variety of concepts to define process structures. For instance, process trains is a concept that is used to denote a fixed sequential series of process stages in which a family of products is produced. The main principle behind process flow scheduling is that scheduling calculations are guided by the process structure ([Taylor and Bolander, 1991](#)). As this approach has been specifically designed for process industries, it obviously is attractive to use to analyse food processing. Next to structuring the production system, [Taylor and Bolander](#) also provide ideas on how scheduling could be performed, which again emphasizes the importance of a structural decomposition.

Finally, we present the capacity group concept and the process routing concept introduced by [Van Donk and Van Dam \(1996\)](#). A capacity group is defined by a number (sometimes one) of interdependent machines in one stage, which perform the same kind of (although not necessarily identical) operations. Process routings are fixed sequential series of operations in which a family of products is produced. These concepts were developed because the authors felt that concepts such as production units or process trains were not very attractive for many process industries and specifically for the food-processing industry. With the capacity group and process routing concepts, the structure of a specific scheduling situation can be analysed, based on typical characteristics as described in section 2.2, and scheduling problems can then be solved for each of the capacity groups.

Application

As production systems in food processing have a lot of connected equipment and shared resources, a thorough understanding of the structure is important. The approaches and concepts mentioned in this section, and summarized in Table 2.3, provide a certain view on scheduling, based on the process characteristics. The first two concepts provide a general structure, where the decoupling point has a customer-specificity viewpoint and the goods flow control and production unit control has a more hierarchical viewpoint. The last two concepts are especially applicable to food. Process flow scheduling provides tools to look at production systems in process industries and sug-

Table 2.3. Overview of the approaches and concepts suggested for the structural decomposition.

Focus	Concept	Main reference
Any industry:	<ul style="list-style-type: none"> • Decoupling point • Goods flow control and production unit control 	Hoekstra and Romme (1992) Bertrand <i>et al.</i> (1990)
Process industry:	<ul style="list-style-type: none"> • Process flow scheduling • Capacity groups and process routings 	Taylor and Bolander (1994) Van Donk and Van Dam (1996)

gest ways to organize the scheduling (*e.g.*, forward, backward). The process routing and capacity group concept focus on a more detailed level to gain a thorough understanding of the production system involved.

This set of approaches is used to decompose the production process to find relatively uncoupled parts and associated scheduling problems, which are easier to solve than the complete scheduling problem. Because scheduling problems are induced through the structure of the production process, decomposition of the production process gives the opportunity to decompose the scheduling problem. Combined with an analysis of specific characteristics encountered in a certain case (see section 2.2), the methods discussed in this section provide the means for the decomposition of the production process.

For example, structural decomposition often results in the grouping of resources. These groups of resources are in some way connected and have to be scheduled together. The connection between the resources can be physically (*e.g.*, through piping) or otherwise (*e.g.*, same operator needed).

In general, the characteristics of the food-processing industry presented in section 2.2 give a good indication of how to decompose the production system. For instance, the capacity group concept will group identical machines together. In scheduling, this might be used to first allocate a number of production tasks to the capacity group, while in a later stage the allocation and sequencing of the tasks can be performed.

As noted by [Van Dam *et al.* \(1998\)](#), a proper insight in the scheduling situation is essential for the design of a scheduling system. The structural decomposition methods described in this section aim to give this insight. In their paper, [Van Dam *et al.*](#) design a scheduling system for the packaging stage in a tobacco company. They also utilise concepts such as grouping to decompose the scheduling problem, which makes it easier to apply OR methods for several scheduling decisions.

2.4.2 Task decomposition

The cognitive process of the scheduler can also be used as a guideline for decomposition. The steps taken and activities performed by human schedulers to perform a scheduling task are identified and used as components in the decomposition. Here, the scheduling task is seen as the combination of actions and decisions of the scheduler to reach certain goals. In task decompositions one mostly speaks of subtasks instead of subproblems. Task analysis is performed to identify these subtasks.

Task decomposition approaches

In order to understand the scheduling process, a thorough task analysis is necessary. Therefore, research methodologies like field studies, action research, or even ethnographic studies (see *e.g.*, Crawford *et al.*, 1999; McKay and Wiers, 2003b) are necessary to obtain the necessary information. Within these methodologies, we identify three useful methods, that are mostly used simultaneously, to gather data.

First, observation can be a good method to acquire a basic understanding of which kind of tasks the scheduler actually performs. Here, tasks are identified on a relatively high level. Examples can be the collection of information or sequencing work for a certain capacity group. Also, the time needed to perform the individual tasks should be recorded. This is partly influenced by the observation that only a relatively small part of the scheduler's time (10–20%) is spent on the actual generation and modification of schedules (see *e.g.*, Crawford and Wiers, 2001).

Secondly, interviews are a logical next step. They can be used to get additional information on the observed tasks. For example, when it was observed that the scheduler discussed a certain element of the schedule with an operator, it is useful to know what goal the scheduler was trying to achieve. Was it just communicating the schedule, or was it an inquiry into the possibilities of relaxing certain constraints.

Finally, protocol analysis (see Ericsson and Simon, 1984) can be a useful tool to obtain further insights into the performed tasks. This is based on 'thinking aloud' sessions with the schedulers performing scheduling tasks. We believe it is especially useful for the actual schedule generation and modification tasks, as these tasks concern a high degree of problem-solving processes. This is also very interesting from a decision support viewpoint, as it is possible to divide the task into smaller subtasks that might be automated

Table 2.4. Examples of possible subtasks (non-exhaustive). Based on [Higgins \(2001\)](#), [Van Wezel et al. \(1996\)](#), and [Wiers \(1997\)](#).

Subtasks		
assigning jobs	monitoring performance	interpreting data
selecting jobs	estimating results	communicating schedules
ranking jobs	administrating production	investigating
counting jobs	evaluating actions	reacting to events

(see also [Van Wezel et al., 1996](#)).

Application

The data gathered are analysed and used to decompose the activity of the scheduler. In the literature, we find several examples of task decompositions. For instance, [Wiers \(1997\)](#) performs a task analysis to identify and redesign subtasks to aid the design of a decision support tool. [Van Wezel et al. \(1996\)](#) develop a framework to facilitate the development of decision support systems, partially based on cognitive task analysis. They also state that a task decomposition will consist of two layers. First, subtasks have to be identified; secondly, the subtasks have to be specified. [Higgins \(2001\)](#) presents a production scheduling paradigm to address decision making in complex systems, which uses [Rasmussen's \(1986\)](#) cognitive work analysis. From these examples, we derived a (non-exhaustive) list of possible subtasks, which is presented in [Table 2.4](#).

Task decomposition is also used in various AI-based methods, such as the constraint-directed scheduling method described by [Smith et al. \(1990\)](#). In this scheduling method, a framework is created consisting of various elements like knowledge sources and a scheduling maintenance system. It uses an opportunistic approach to guide the decision-making process, which is a commonly used approach (see also [Hayes-Roth and Hayes-Roth, 1979](#)). Based on this framework, a factory scheduling system is created.

Another important aspect in task decompositions is the fact that schedulers use 'enriched' data, which was demonstrated by [McKay et al. \(1995\)](#). For system developers, this kind of information is only available after a task analysis has been performed and gives useful insights in the scheduling process, although it may not be possible to 'computerise' this enriched data.

Considering the strength of human schedulers mentioned, the task decomposition of scheduling is promising. Research in this area has, until now, mostly stressed the importance of the human element, but combining com-

puterisation and human control still seems to be a difficult topic (*e.g.*, Crawford *et al.*, 1999). Useful insights on this topic are provided by McKay *et al.* (1995), who studied the encodability of heuristics used by a scheduler.

2.5 Context-based analysis methodology

2.5.1 Description of the approach

In previous sections, both structural decompositions and task decompositions were explained. It was also stated that the structure of the production process and the task of the scheduler are the elements we understand to be the context of scheduling. Both decomposition approaches have promising results. A good understanding of the production process gives opportunities to improve the decision-making in scheduling, whereas the task approach helps in supporting the task execution and in clarifying the relations between tasks.

In the context-based approach we advocate, both the structural and the task decomposition are used to represent the scheduling situation. The structural elements provide insight into the product and production process characteristics, as discussed in section 2.2. Some of the elements can have a clear link to a mathematical approach. Elements from the cognitive side cannot always be analysed in this mathematical way, but they add knowledge and possibilities to the scheduling process and its organisation (see *e.g.*, McKay *et al.*, 1995). Combining structural with cognitive elements provides the opportunity to verify insights obtained in analysis of specific characteristics using insights from a task analysis of the schedulers' task. Also, a good knowledge of structural elements is necessary in understanding the scheduling task.

The framework we propose is presented in Figure 2.2. The structural and task decomposition are based on the concepts and methods presented in Section 2.4. For the structural decomposition, the first step is the determination of relevant characteristics (see section 2.2). Secondly, the identification of the structure, using concepts like process routings, process trains, goods flow control and the decoupling point. After the identification of the structure, a specification can be made, using concepts such as capacity groups and production units. A similar three-step approach is used for the task decomposition. First, the scheduling task has to be determined. Secondly, scheduling subtasks are identified using *e.g.* observation and interviews. Thirdly, a more thorough study based on thinking aloud and protocol analysis is performed to specify the subtasks.

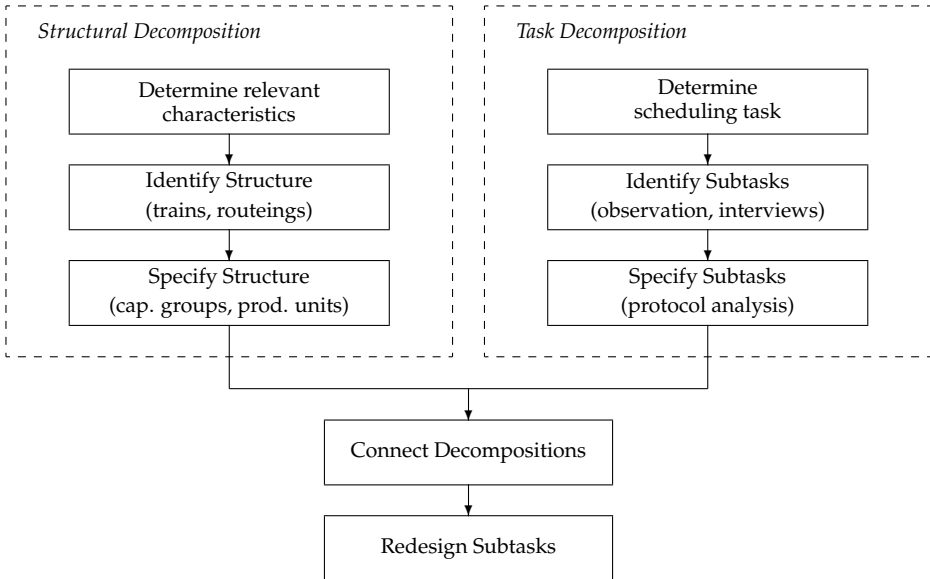

Figure 2.2. Schematic representation of the context-based approach to analyse scheduling problems.

The specific applicability to the food-processing industry is found in the choice for methods to perform the structural decomposition. In section 2.2, several characteristics were identified as common for the food-processing industry. The presence of these characteristics makes certain decomposition methods more useful than others. For instance, the capacity group concept is very useful in environments where we see the use of shared resources and in situations where the same operations can be performed with different productivity rates. A concept like process trains would be less useful in this case, as it quickly encompasses whole production systems in food processing (where a lot of the equipment is shared or connected).

Concerning the connection of the decompositions, it is possible to specify relations between the scheduling subtasks and elements from the structural decomposition. It is unlikely that this will result in a collection of one-to-one relations. The final network of relations will probably consist of one-to-one, one-to-many, and many-to-many relations (as illustrated in Figure 2.3).

A related issue is the connection between tasks. Not all tasks need to be directly sequential or have a fixed order. However, tasks that would be identified in a holistic sense often have several, more visible, occurrences that do have their place in a sequence. For instance, the gathering of information could be seen as a holistic activity, which becomes more visible in combina-

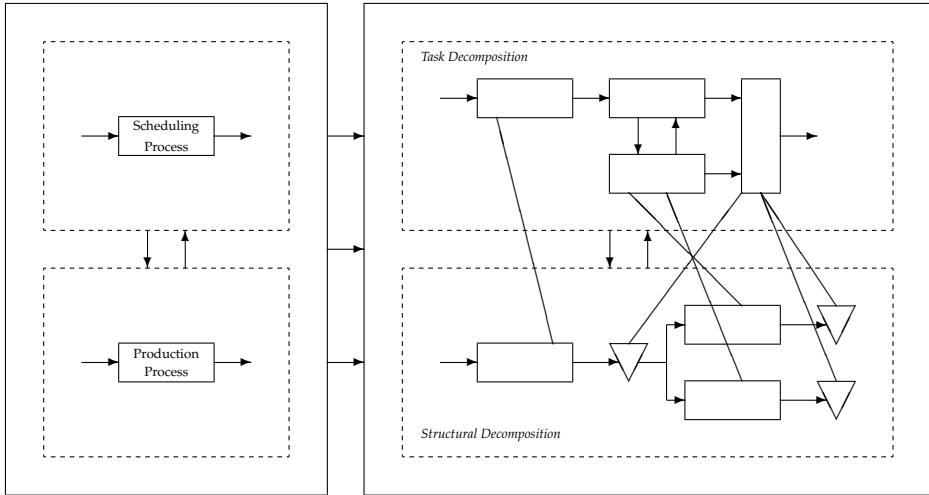

Figure 2.3. Decomposition in the context-based approach.

tion with subtasks that use specific information.

If independent subnetworks (sets of subtasks) arise from the decomposition, these can be evaluated in the light of possible computerisation (see also McKay *et al.*, 1995). For each individual subnetwork, it can be decided whether or not it is suitable for computerisation. However, there are also possibilities between no computerisation and full computerisation. In some cases, the solution may be between these extremes. For instance, in a sequencing task for a certain capacity group, the computer could generate possible scenarios, from which the scheduler can pick the most attractive sequence. Note that this does not necessarily have to be the sequence that the computer would think to be optimal.

The resulting framework has three important potential results. First, the identification of independent sets of subtasks, which can possibly be (partly) supported by scheduling algorithms or heuristics. In addition, the relations between the scheduling tasks, as well as the relations between scheduling tasks and production structure, are clarified. This provides two additional outcomes: it can be helpful in evaluating the organisational structure; and it reveals the information structure wherein scheduling is embedded.

Because of the first result, the framework can also make use of the enormous amount of scheduling research in the OR and AI communities. Some subtasks could be computerized or supported by heuristic or algorithmic approaches, while other subtasks could remain with the scheduler. We believe

that this could improve the practical use of decision support systems, because the resulting system would have its basis in the elements from the scheduling task.

2.5.2 Illustrative example

To illustrate our framework, we present a small example from a meat products company. In this example, task analysis resulted, among others, in numerous rules-of-thumb used by the scheduler. In the scheduling of a certain capacity group, one of the rules used to assign capacity was that two particular packaging lines were never to be used at the same time. Initially, it was unclear why this rule was used. Based on structural analysis, the underlying reasoning turned out to be that a sterilisation process, situated just after these packaging lines (in the same process routing), could only process the output of one line at once. This reason became clear after evaluating what food-specific characteristics were present in the company. The characteristics ‘connectivity’, ‘shared resources’, and ‘production rate determined by capacity’ describe the situation. Figure 2.4 presents the relevant parts of the structural and task decomposition.

This example also illustrates the three potential outcomes mentioned in the previous section. First, regarding the use of algorithms to support subtasks, it is clear that ‘sequencing packaging’ could be mathematically solved. Secondly, the organisational structure can be evaluated on the basis of the network of subtasks. For each of the subtasks, responsible parties can be identified. These could also be reallocated. For example, in this small example, it wouldn’t make sense if the subtasks were divided among several people. The person who assigns the capacity and sequences the packaging lines should also be able to negotiate the schedule, as he or she knows the underlying objectives. Finally, the information structure is revealed. The information for assignment of products to the packaging lines is required on a higher level (*i.e.* capacity group) than the packaging line information needed to sequence the packaging lines.

2.6 Conclusions

In this paper, the scheduling situation in the food-processing industry is studied, and a context-based analysis methodology for scheduling problems is proposed. The emphasis of this study is on the context of scheduling, in which we make a distinction between the structural and the task context.

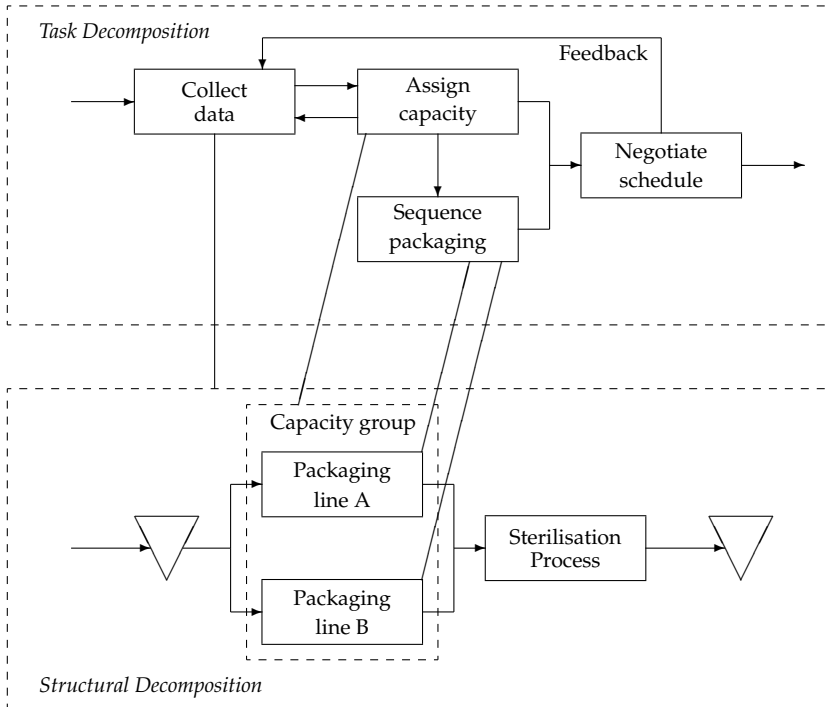

Figure 2.4. Schematic representation of a part of the structural and task decomposition in the example of the context-based approach.

The structural context is the structure of the production process, especially focused on product and production characteristics; the task context is the cognitive decision-making task of the scheduler. In previous research, the structural insights have hardly been studied and a combination between structural and cognitive approaches has also had little attention.

To develop a context-based view on scheduling problems in the food-processing industry, we first reviewed the industry-specific characteristics. This overview of characteristics gives a reasonable representation of the industry and shows the complexity of its scheduling problems. Secondly, a number of research areas are discussed to review their capabilities to deal with the complexity of the scheduling situation. Thirdly, we discussed structural decompositions and task decompositions, which are combined into our context-based approach in the final part of the paper.

Our combination of structural and cognitive insights can be positioned in one of the six high-impact research issues recently identified by McKay *et al.* (2002). They mention ‘task design’ as one of these research issues, and this

concerns, among others, the cooperation between the scheduler and the support system. This support system is often based on decomposition, which is very important for its usability. The cooperation could benefit from using structural and cognitive insights in the decomposition process. With this study, we add to the ongoing discussion to bridge the gap between theory and practice in scheduling research.

Application of the context-based approach in real-life food-processing companies gives a good insight in the scheduling problems. Furthermore, it seems possible to make better use of the existing body of knowledge within the world of scheduling research, and to evaluate the organization and information structure around the scheduling problems.

We realise that our context-based approach also has limitations. More is needed to apply it in different situations and to better relate it to the characteristics of food processing. We also acknowledge the importance of the user of the methodology. After a fairly generic way of identifying a structural and a task decomposition, the analysis part might be more subjective. The user still has to evaluate the resulting decompositions, and judge the possibilities for computerisation and the organisational aspects. However, with our approach, we believe that a thorough study of the structural and cognitive elements is a significant step in this process.

Topics for further research can be found in the use of OR and AI techniques for the construction of decision support for subproblems in the decomposition. In this paper, a conceptual contribution is presented. The application in real-life settings is needed to test the context-based approach in practical scheduling situations.

The method proposed in this paper is designed for the food-processing industry. The industry-specific character lies mostly in the choice for methods in the structural decomposition. We think the approach could also be used in other types of industry, if the choice for methods to be used in the structural decomposition is suitable for the specific industry. For instance, due to the high degree of connectivity between equipment found in food processing, we use concepts like process routing to analyse the dependence between the scheduling decisions. For discrete industries, workstations often operate more independently. Therefore, process routings may probably have other effects.